

The Hemagglutinin/Esterase Gene of Human Coronavirus Strain OC43: Phylogenetic Relationships to Bovine and Murine Coronaviruses and Influenza C Virus

XUMING ZHANG, KONSTANTIN G. KOUSOULAS, AND JOHANNES STORZ¹

*Department of Veterinary Microbiology and Parasitology, School of Veterinary Medicine,
Louisiana State University, Baton Rouge, Louisiana 70803*

Received August 5, 1991; accepted September 18, 1991

The complete nucleotide sequences of the hemagglutinin/esterase (HE) genes of human coronavirus (HCV) strain OC43 and bovine respiratory coronavirus (BRCV) strain G95 were determined from single-stranded cDNA fragments generated by reverse transcription of virus-specific mRNAs and amplified by polymerase chain reaction. An open reading frame of 1272 nucleotides was identified as the putative HE gene by homology to the bovine coronavirus HE gene. This open reading frame encodes a protein of 424 amino acids with an estimated molecular weight of 47.7 kDa. Ten potential *N*-linked glycosylation sites were predicted in the HE protein of HCV-OC43 while nine of them were present in BRCV-G95. Fourteen cysteine residues were conserved in the HE proteins of both viruses. Two hydrophobic sequences at the *N*-terminus and the *C*-terminus may serve as signal peptide and transmembrane anchoring domain, respectively. The predicted HE protein of HCV-OC43 was 95% identical to the HEs of BRCV-G95 and other bovine coronaviruses, and 60% identical to the HEs of mouse hepatitis viruses. Phylogenetic analysis suggests that the HE genes of coronaviruses and influenza C virus have a common ancestral origin, and that bovine coronaviruses and HCV-OC43 are closely related. © 1992 Academic Press, Inc.

Coronaviruses possess a single-stranded, nonsegmented RNA genome of positive polarity (1, 2) and are associated with a variety of diseases in man and animals (3-5). Coronaviruses are divided into two major antigenic groups. The first group includes human coronavirus OC43 (HCV-OC43), bovine coronavirus (BCV), mouse hepatitis virus (MHV), and hemagglutinating encephalomyelitis virus of swine (HEV) (2, 5). HCV-OC43 causes respiratory infection of man similar to those of influenza viruses (6). BCV causes enteritis of newborn calves and is also considered to be an etiological factor of respiratory diseases of calves (7, 8). MHV can infect different organs, causing enteric, respiratory, and neurological diseases (5, 9). A unique property of coronaviruses within this antigenic cluster is the presence of the hemagglutinin/esterase (HE) gene. The genome of MHV-A59 contains an open reading frame (ORF), which may code for an HE protein. However, the HE is not expressed in infected cells (10, 11, 23). The second group, which includes HCV strain 229E, avian infectious bronchitis virus (IBV), porcine transmissible gastroenteritis virus, and feline infectious peritonitis virus, lacks an HE gene (2, 5).

The HE glycoproteins of HCV-OC43, BCV, MHV-JHM, and HEV possess hemagglutination (receptor-

binding) and acetylerase (receptor-destroying) activities similar to the HE (or HEF) glycoprotein of influenza C virus (ICV) (12-20). It was shown that the HE glycoprotein of BCV strain Quebec induces neutralizing antibodies both *in vitro* and *in vivo* and thus, is important in viral infectivity (21, 22). It is evidently not required for viral infectivity in MHV-A59 and MHV-JHM (11). The role of the HE gene and its protein in coronavirus evolution, replication, and pathogenesis remains unclear.

The exact genomic organization of HCV-OC43 is not known. Antigenic and nucleic acid hybridization studies indicate that the HCV-OC43 is closely related to BCV (23-25). By analogy to BCV, the order of the genes coding for the structural proteins probably is 5'-HE-S-M-N-3'. Recently, the N gene of HCV-OC43 was sequenced, and it was found to be similar to BCV N gene (97.5% amino acid sequence homology) (26). The origin and evolutionary relationships among the HE genes of hemagglutinating coronaviruses isolated from different species are poorly understood. To elucidate the molecular evolution of the coronavirus HE genes, we sequenced the HE genes of HCV-OC43, a bovine respiratory coronavirus (BRCV), a virulent, and an avirulent BCV strains. We report here the complete nucleotide sequence of the HE genes of HCV-OC43 and BRCV-G95, and their phylogenetic relatedness to BCVs, MHV, and ICV.

HCV-OC43 was obtained from the American Type Culture Collection (ATCC, 759-VR) and propagated in human rectal tumor (HRT-18) cells as described previ-

Sequence data from this article have been deposited with the EMBL/Genbank Libraries under Accession Nos. M76373 for HCV-OC43 and M80842 for BRCV-G95.

¹ To whom reprint requests should be addressed.

ously (27). A bovine respiratory coronavirus strain Giessen 89-4595 (G95) was kindly provided by Dr. W. Herbst, Institute of Hygiene and Infectious Diseases of Animals, Justus Liebig University Giessen, Germany. This virus was originally isolated from nasal swabs of a calf suffering from respiratory disorder, and propagated in HRT-18 cells. Isolation and purification of viral RNA, cDNA synthesis, double-stranded (ds) cDNA amplification and single-stranded (ss) cDNA production by polymerase chain reaction (PCR), as well as DNA sequencing were performed as described previously (28, 44).

Primers were designed to generate cDNA fragments from virus-specific mRNAs by reverse transcription and PCR amplification, based on the high degree of genomic similarity between HCV-OC43 and BCVs (25, 26). These primers were previously used for amplification and sequencing of BCV S and HE genes (28, 44). PCR-generated cDNA fragments were directly sequenced in both directions. Analysis of the sequences revealed that a large ORF of 1272 nucleotides was identical in size to the HE genes of BCVs (29, 30, 44). This ORF terminated 14 nucleotides upstream from the S gene (Zhang *et al.*, unpublished data), and encoded a protein of 424 amino acid residues with an estimated molecular weight of 47.7 kDa (Figs. 1 and 2). Two identical sequences (CTAAAC), similar to the consensus intergenic sequence upstream of the HCV-OC43 N gene (CTAAAT) (26) and identical to the consensus sequence upstream of BCV HE and S genes, were found 16 nt upstream of the predicted initiation codon (at nucleotides 16 to 18) for the HE protein and 8 nt downstream from the termination codon, respectively. Hydrophobic analysis of the predicted amino acid sequence indicated that the putative HE protein possessed the characteristics of a membrane protein. Specifically, a hydrophobic stretch of 15 amino acids at the N-terminus may serve as signal peptide with a cleavage site between amino acids 15 and 16 (30, 31, 44). Another hydrophobic amino acid sequence near the C-terminus (amino acids 389 to 414) may serve as the transmembrane domain anchoring the protein in the viral envelope. A hydrophilic sequence of 10 amino acids at the C-terminus may serve as an intravirion-domain. Ten potential N-linked glycosylation sites were predicted in the HE protein of HCV-OC43 while nine of them were present in that of BRCV-G95. Two internal ORFs were predicted within the large ORF extending from nt 107 to 517 and from 976 to 1228. By analogy to BCV HE gene, these results suggest that the predicted large ORF 2b represents mRNA 2-1 of HCV-OC43 and BRCV-G95, encoding the HE glycoprotein.

The predicted amino acid sequences of the HE genes from HCV-OC43 and BRCV-G95 (Fig. 1), BCV-

Mebus (30), BCV-Quebec (29), BCV-L9, BCV-LY138 (44), MHV-A59 (10), MHV-JHM (11) were aligned using the programs of the University of Wisconsin Genetic Computer Group software package, version 6.1. The alignment revealed that the HE gene of HCV-OC43 was more closely related to BRCV-95 and BCVs than to MHVs. Nucleotide and amino acid sequences among HCV-OC43, BRCV-G95, and BCVs were 95.8 to 96.3% and 94.1 to 94.8% identical, respectively, while the amino acid sequence identity between HCV-OC43 and MHVs was approximately 60%. Fourteen cysteine residues were strictly conserved in the HE proteins of HCV-OC43, BRCV-G95, BCVs, and MHVs. The MHV-JHM had 15 amino acids and two cysteine residues more than HCV-OC43 and BRCV-G95. The alignment indicated that the eight HE genes among coronaviruses can be divided into two groups. The first group includes HCV-OC43, BRCV-G95, and all BCVs, and the second group includes MHV-JHM and MHV-A59.

To identify a possible evolutionary pathway for the HE gene of coronaviruses, we compared the coronavirus HE genes with the ICV HE gene. An alignment of the predicted amino acid sequences is shown in Fig. 2. In this alignment, the ICV HE1 subunit shows a sequence identity of approximate 28.2% with the HE protein of HCV-OC43, BRCV-G95, and BCVs, and 26.3% with the HE protein of MHVs. The alignment shows that several regions are completely identical. Most importantly, the putative acetyltransferase active site (F-G-D-S) (at amino acids 72 to 75 in Fig. 2) is conserved in all HE proteins of human, bovine, and murine coronaviruses and ICV. Ten of the 14 cysteine residue positions of HCV-OC43 are conserved among all HE proteins compared. These data suggest that these proteins may be evolutionarily related to each other.

DNA sequences for each gene were optimally aligned based on the alignment of their respective amino acid sequences (Fig. 2). A maximum parsimony analysis was performed on the aligned DNA sequences to predict possible phylogenetic relationships among coronaviruses (detailed methodology for the phylogenetic, computer-assisted analysis is described in the legend of Fig. 3). Cladistic analysis of the DNA sequence data resulted in a single phylogenetic hypothesis (phylogram) with a total length of 1503 steps and a rescaled consistency index of 0.962. This analysis suggested that all coronaviruses were divided in two clades. One clade included HCV-OC43, BRCV-G95, and BCVs. The other clade consisted of MHV-JHM and MHV-A59. Neither coronavirus clade is derived from the other. Within the clades, all BCVs were closely related taxa to HCV-OC43, and the MHV-JHM and MHV-A59 were sister taxa. The phylogram sug-

BRCV-G95		G	TC	G A	
HCV-OC43	CTAAACTCAGTGAAAATGTTTTGCTTCCTAGATTTATTCTAGTTAGCTGCATAATTGGTAGCTTAGGTTTTTACAACCCTCCTACCAATGTTGTTTCGC				100
	*****	MetPheLeuLeuProArgPheIleLeuValSerCysIleIleGlySerLeuGlyPheTyrAsnProProThrAsnValValSerH			
BRCV-G95	T	G	C	G	
HCV-OC43	ATGTAATGGAGATTGGTTTTATTGGTGACAGTCGTTTCAGATTGTAATCATATTGTTAATATCAACCCCATAAATTATCTTATATGGACCTTAATCC				200
		isValAsnGlyAspTrpPheLeuPheGlyAspSerArgSerAspCysAsnHisIleValAsnIleAsnProHisAsnTyrSerTyrMetAspLeuAsnPr			
		IORF1 MetGluIleGlyPheTyrLeuValThrValValGlnIleValIleIleLeuLeuIleSerThrProIleIleIleLeuIleTrpThrLeuIleL			
BRCV-G95	CC				
HCV-OC43	TGTTCTGTGTGATTCTGGTAAAATATCATCTAAAGCTGGCACTCCATTTTTAGGAGTTTTCACTTTACCGATTTTTATAATTACACAGGCGAAGGTCAA				300
		oValLeuCysAspSerGlyLysIleSerSerLysAlaGlyAsnSerIlePheArgSerPheHisPheThrAspPheTyrAsnTyrThrGlyGluGlyGln			
		euPheCysValIleLeuValLysTyrHisLeuLysLeuAlaThrProPheLeuGlyValPheThrLeuProIlePheIleIleThrGlnAlaLysValAs			
BRCV-G95		C A C			
HCV-OC43	CAAATTATTTTTATGAGGGTGTAAATTTACGCCCTTATCATGCCTTTAAATGCAACCGTTCTGGTAGTAATGATATTGGATGCAGAATAAAGGCTTGT				400
		GlnIleIlePheTyrGluGlyValAsnPheThrProTyrHisAlaPheLysCysAsnArgSerGlySerAsnAspIleTrpMetGlnAsnLysGlyLeuP			
		nLysLeuPhePheMetArgValLeuIleLeuArgLeuIleMetProLeuAsnAlaThrValLeuValValMetIlePheGlyCysArgIleLysAlaCys			
BRCV-G95	C		C	T	T
HCV-OC43	TTTATACTCAGGTTTATAAGAATATGGCTGTGTATCGCAGCCTTACTTTTGTTAATGTACCATATGTTTATAATGGCTCCGCACAAGCTACAGCTCTTTG				500
		heTyrThrGlnValTyrLysAsnMetAlaValTyrArgSerLeuThrPheValAsnValProTyrValTyrAsnGlySerAlaGlnAlaThrAlaLeuCy			
		PheIleLeuArgPheIleArgIleTrpLeuCysIleAlaAlaLeuLeuLeuMetTyrHisMetPheIleMetAlaProHisLysLeuGlnLeuPheV			
BRCV-G95		T	G G	T T	
HCV-OC43	TAAATCTGGTAGTTTAGTCCTTAATAACCCCTGCATATATAGCTCCTCAAGCTAACTCTGGGGATTATTATTATAAGGTTGAAGCTGATTTTTATTGTC				600
		sLysSerGlySerLeuValLeuAsnAsnProAlaTyrIleAlaProGlnAlaAsnSerGlyAspTyrTyrTyrLysValGluAlaAspPheTyrLeuSer			
		alAsnLeuValVal---			
BRCV-G95					
HCV-OC43	GGTTGTGACGAGTATATCGTACCCTTGTATTTTAACGGCAAGTTTTGTGCGAATACAAAGTATTATGATGATAGTCAATATATTTTAAATAAGACA				700
		GlyCysAspGluTyrIleValProLeuCysIlePheAsnGlyLysPheLeuSerAsnThrLysTyrTyrAspAspSerGlnTyrTyrPheAsnLysAspT			
BRCV-G95		T	T	C	C
HCV-OC43	CTGGTGTATTATGAGTCTCAATCTACAGAAACCATTACCCTGGTTTTGATCTTAATTTGTTATTATTAGTTTTACCCTCTGGTAATTATTAGCCAT				800
		hrGlyValIleTyrGlyLeuAsnSerThrGluThrIleThrThrGlyPheAspLeuAsnCysTyrTyrLeuValLeuProSerGlyAsnTyrLeuAlaIl			
BRCV-G95		T		C	
HCV-OC43	TTCAAATGAGCTATTGTTAACTGTTCTACGAAAGCAATCTGCTTAATAAGCGTAAGGATTTTACGCCTGTACAGGTTGTGATTCGCGGTGGAACAAT				900
		eSerAsnGluLeuLeuLeuThrValProThrLysAlaIleCysLeuAsnLysArgLysAspPheThrProValGlnValValAspSerArgTrpAsnAsn			
BRCV-G95		A	C	C	C
HCV-OC43	GCCAGGAGCTGATAACATGACGGCGGTTGCTGTCAACCTCCGTACTGTTATTTTCGTAATCTACTACCAACTATGTTGGTGTATTATGATTTAATC				1000
		AlaArgGlnSerAspAsnMetThrAlaValAlaCysGlnProProTyrCysTyrPheArgAsnSerThrThrAsnTyrValGlyValTyrAspIleAsnH			
		IORF2 MetLeuValPheMetIleLeuIle			
BRCV-G95		G	C	G	A
HCV-OC43	ATGGAGATGCTGGTTTTACTAGCATACTTAGTGGTTTGTATATAAATTCACCTTGTTTTTTCGCAGCAAGCGTTTTTAGGTATGATAATGTTAGCAGTGT				1100
		isGlyAspAlaGlyPheThrSerIleLeuSerGlyLeuLeuTyrAsnSerProCysPheSerGlnGlnGlyValPheArgTyrAspAsnValSerSerVa			
		MetGluMetLeuValLeuLeuAlaTyrLeuValValCysTyrIleIleHisLeuValPheArgSerLysAlaPheLeuGlyMetIleMetLeuAlaValS			
BRCV-G95	T	G	T	C C	G T
HCV-OC43	CTGGCTCTCTACCCCTATGGCAGATGTCCCACTGCTGCTGATATTAATATCCCTGATTTACCCATTTGTGTGTATGATCCGCTACCAGTTATTTTGCTT				1200
		lTrpProLeuTyrProTyrGlyArgCysProThrAlaAlaAspIleAsnIleProAspLeuProIleCysValTyrAspProLeuProValIleLeuLeu			
		erGlyLeuSerThrProMetAlaAspValProLeuLeuLeuIleLeuIleSerLeuIleTyrProPheValCysMetIleArgTyrGlnLeuPheCysLe			
BRCV-G95		T	G CA		
HCV-OC43	GGCATTCTTTGGGCGTTGCGATTGTAATTTAGTAGTTTTGTTGTTATATTTTATGGTGGATAATGGTACTAGGCTGCATGATGCTTAGACCATAATCT				1300
		GlyIleLeuLeuGlyValAlaIleValIleIleValValLeuLeuLeuTyrPheMetValAspAsnGlyThrArgLeuHisAspAla---			**
		uAlaPhePheTrpAlaLeuArgLeu---			
BRCV-G95					
HCV-OC43	AAAC 1304				

Fig. 1. Nucleotide and deduced amino acid sequences of the HE gene of HCV-OC43 and BRCV-G95. The primers 3'S95 (5'-ATGGAAACCGTAGTAGTACACTT-3') and 5'HE (5'-GGTTTTATGAATCTCCAGTTGAA-3') were used for cDNA synthesis and PCR amplification. DNA sequencing was carried out with the modified dideoxynucleotide chain termination procedure (43) using Sequenase (USB, Cleveland, OH). Sequences were analyzed with the aid of the Sequence Analysis Software Package of the Genetics Computer Group of the University of Wisconsin and the MacVector Software (IBI, New Haven, CT). The consensus sequences (CTAAAC) are indicated by asterisks. The predicted signal peptide and intramembrane anchoring sequences are marked by (~). Ten potential N-linked glycosylation sites are underlined. The putative acetyltransferase active site (FGDS) is shown in boldcase. The amino acid sequences of two possible internal ORFs are displayed under the amino acid sequence of the large ORF. The nucleotide sequences of the HE gene of BRCV-G95, which differ from those of HCV-OC43, are displayed above the nucleotide sequence of HCV-OC43.

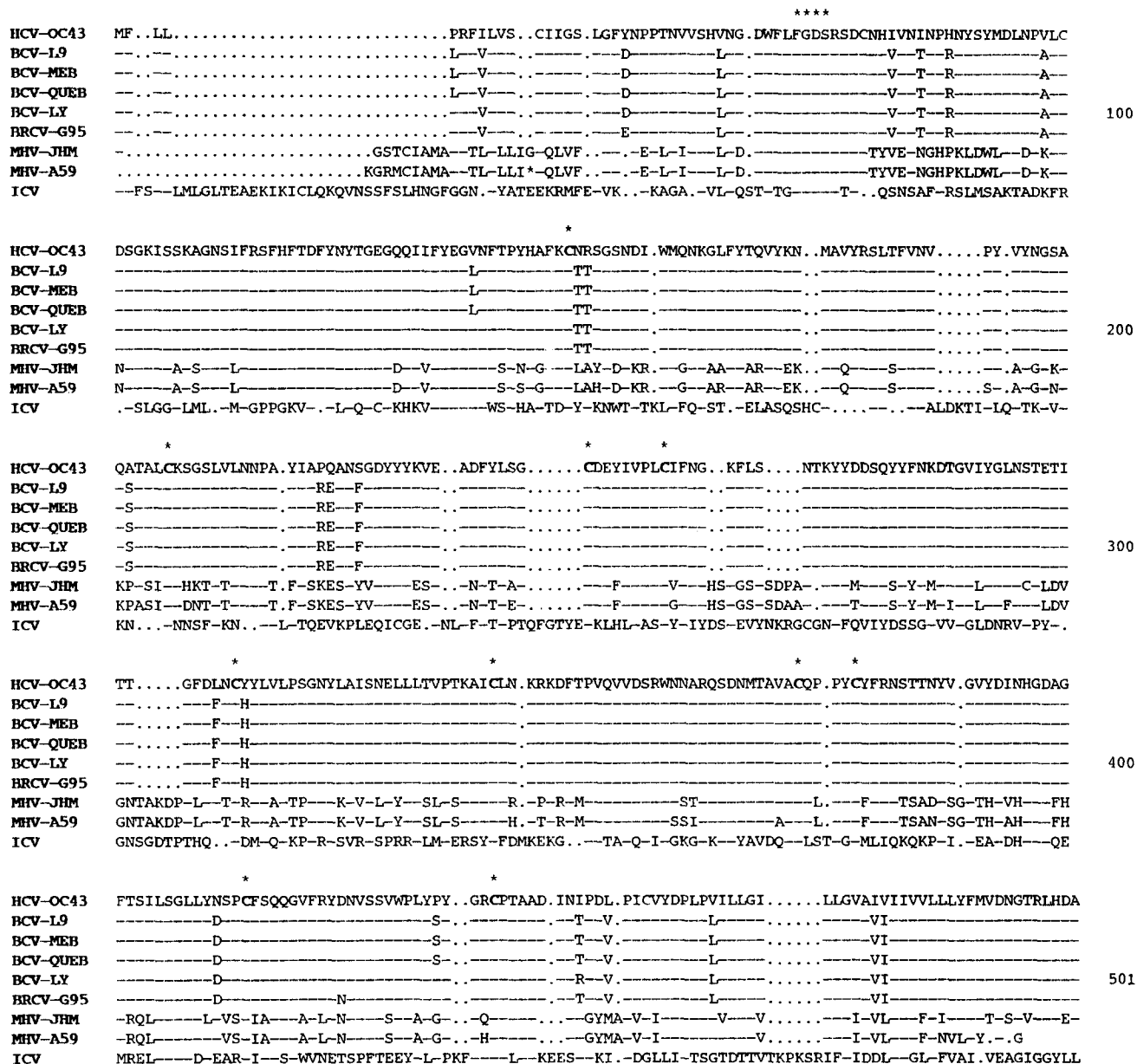

Fig. 2. Comparison of the amino acid sequences of the HE proteins among human, bovine, and murine coronaviruses and influenza C virus. The deduced amino acid sequences were aligned manually. The conserved cysteine residues and the putative esterase active sites (FGDS) are marked by asterisks on the top. Dash (-) indicates amino acids identical to the first sequence. Dot (·) denotes gaps introduced to the sequences for maximum alignment. The sequence for BCV-Mebus, BCV-Quebec, MHV-JHM, MHV-A59, ICV were obtained from Refs. 30, 29, 11, and 10, respectively. The sequences for BCV-L9, BCV-LY138 were obtained from recent work (44).

gested a common ancestor of this antigenic group of coronaviruses. The highly cell-adapted strains BCV-L9, BCV-Quebec, and BCV-Mebus are closely related to the wild-types BCV-LY138 and BRCV-G95. We excluded these strains in the final phylogenetic analysis, because their close relationships resulted in collapsed branches in the phylogenetic tree. We further attempted to analyze the relationship among the HE genes of selected coronaviruses and ICV based on these results using limited DNA sequence information,

and assuming ICV as outgroup. The highly variable regions (positions 19–185, 235–365, 451–1046, 1255–1295, 1351–1430, and 1459–1503) were excluded because they were not aligned with confidence. We identified 125 phylogenetically informative sites (variable sites with at least two taxa potentially sharing a derived base) from 439 aligned base positions. The phylogram shows an almost identical topology for the coronaviral ingroup obtained by the previous analysis (Fig. 3).

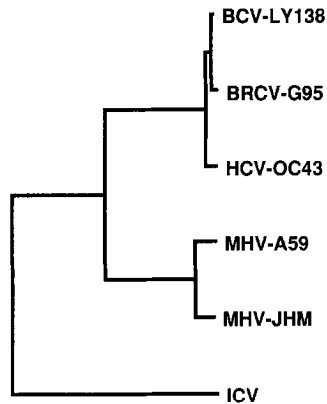

FIG. 3. Phylogenetic tree for the HE gene nucleotide sequences of human, bovine, and murine coronaviruses and ICV. The complete HE gene sequences of HCV-OC43, BRCV-G95, MHV-JHM (11), MHV-A59 (10), and BCV-LY138 (44), and a partial HE gene sequence of ICV (32) were used for this phylogram. The DNA sequences were aligned based on their deduced amino acid sequence alignment as shown in Fig. 2. The data were analyzed with the software package PAUP (Phylogenetic Analysis Using Parsimony, version 3.0g, D. Swofford, National Historical Survey, IL) using the MULPARS heuristic search option with tree bisection-reconnection (TBR) branch-swapping. From the alignment, 462 phylogenetically informative sites were identified from 1503 aligned base positions per taxon. Horizontal distance (branch-length) is proportional to the number of inferred character changes. Vertical lines are for spacing branches and labels.

Since the HCV-OC43 and ICV infect similar tissues in human subjects, the significant sequence homology between the HE genes of the two viruses suggests that coinfection of an ancestral coronavirus with ICV followed by recombination may have given rise to HCV-OC43. This was also proposed by Luytjes *et al.* (10). Phylogenetic analysis also suggests that the HE genes of coronaviruses and ICV may originate from a common ancestor. It is worth noting that the HE protein of ICV contains receptor-binding, acetylase and fusion activities while that of coronaviruses contains only the receptor-binding and acetylase activities. The fusion function of ICV is associated with the *N*-terminal hydrophobic region of the HE2 subunit of the HE protein (17–19, 32). A similar hydrophobic domain was not found in the coronavirus HE protein.

The high similarity between the HE proteins of HCV-OC43 and BCVs (95% identity on the average) suggests that both viruses are very closely related. This hypothesis is also supported by the tree branch distance in the phylogenetic analysis shown in Fig. 3. Interestingly, the HE of HCV-OC43 is more closely related to those of BRCV-G95 and the wild-type, virulent strain BCV-LY138 than to that of the cell-culture adapted avirulent strain BCV-L9. The wild-type strain BCV-LY138 does not replicate in numerous bovine

cells *in vitro*, but it grows readily in human cells (HRT-18) without requiring prior adaptation (27, 33, 34). Since these polarized human cells retain many features of primary epithelial cells, infection by BCV suggests that BCV may also infect humans, and therefore, it is a zoonotic virus (23, 35).

We previously reported a case of human diarrhea caused by BCV-LY138, in which the virus was identified from the infected patient (35). Recently, we found that BRCV-G95 exhibited almost identical cytopathology *in vitro* to the wild-type virulent strains BCV-LY138 (data not shown). The HCV-OC43, BCVs, and BRCV-G95 differed only in few amino acids in the HE, and their putative acetylase active sites were conserved (see Fig. 2). *O*-acetylneuraminic acid was shown to be the major determinant for ICV (36–38). HCV-OC43, BCVs, and BRCV-G95 probably recognize this receptor on the surface of many different epithelial cells. They may be able to replicate in epithelial cells of both respiratory and intestinal tracts, and to cross species-barriers causing diseases in heterologous hosts. However, HCV-OC43 primarily causes respiratory diseases and BCVs cause enteritis. The ability of these viruses to replicate in different organs and to cause different clinical symptoms is probably due to multiple amino acid differences occurring within several viral proteins. The S protein of MHV was shown to be important in tissue tropism (39).

Recently, it was reported that turkey enteric coronavirus is antigenically and genomically closely related to BCVs (40), and similar functions were found in the HE protein of HEV (20). Whether swines or turkeys may also serve as reservoir (mixing-vessel) for coronavirus recombination in nature, as it was proposed for influenza A viruses (41), remains to be elucidated. It is worth noting that ICV was also isolated from pigs (42). It will be worthwhile to compare the HE genes among these coronaviruses. Comparison of the remaining genes with HCV-OC43 and BCVs will provide further insight into their evolution and host cell tropism.

ACKNOWLEDGMENTS

This work was supported by Grants 86-CRSR-2-2871 and 89-34116-4675 from the United States Department of Agriculture, and the Louisiana Education Quality Support Fund of the Board of Regents, State of Louisiana, to J.S. and K.G.K., and in part by Grant AI87886 from the National Institute of Health to K.G.K. X.M.Z. is a postdoctoral fellow. We thank Mamie Burrell for virus propagation, and Dr. B. Kaltenboeck for assistance in the phylogenetic analysis. This publication is identified as 108 of the VMP Gene Probe and Expression Systems Laboratory.

REFERENCES

1. CAVANAGH, D., BRIAN, D. A., ENJUANES, L., HOLMES, K. V., LAI, M. M. C., LAUDE, H., SIDDELL, S. G., SPAAN, W., TAGUCHI, F., and TALBOT, P., *J. Virol.* **176**, 306–307 (1990).

2. SPAAN, W., CAVANAGH, D., and HORZINEK, M. C., *J. Gen. Virol.* **69**, 2939–2952 (1988).
3. MCINTOSH, K., KAPIKIAN, A. Z., TURNER, H. C., HARTLEY, J. W., PARROT, R. H., and CHANOCK, R. M., *Am. J. Epidemiol.* **91**, 585–592 (1970).
4. MCINTOSH, K., *Curr. Top. Microbiol. Immunol.* **63**, 85–129 (1974).
5. WEGE, H., SIDDELL, S., and TER MEULEN, V., *Curr. Top. Microbiol. Immunol.* **99**, 165–200 (1982).
6. MCINTOSH, K., DEES, J. H., BECKER, W. B., KAPIKIAN, and CHANOCK, R. M., *Proc. Natl. Acad. Sci. USA* **57**, 933–940 (1967).
7. MEBUS, C. A., STAIR, E. L., RHODES, M. B., and TWIEHAUS, M. J., *Am. J. Vet. Res.* **34**, 145–150 (1973).
8. REYNOLDS, D. J., DEBNEY, T. G., HALL, G. A., THOMAS, L. H., and PARSONS, K. R., *Arch. Virol.* **85**, 71–83 (1985).
9. LAI, M. M. C., and STOHLMAN, S. A., *J. Virol.* **26**, 236–242 (1978).
10. LUYTJES, W., BREDBEKE, P. J., NOTEN, A. F., HORZINEK, M. C., and SPAAN, W. J., *Virology* **166**, 415–22 (1988).
11. SHIEH, C. K., LEE, H. J., YOKOMORI, K., LA MONICA, N., MAKINO, S., and LAI, M. M. C., *J. Virol.* **63**, 3729–3736 (1989).
12. VLASAK, R., KRYSAL, M., NACHT, M., and PALESE, P., *Virology* **160**, 419–425 (1987).
13. VLASAK, R., LUYTJES, W., LEIDER, J., SPAAN, W., and PALESE, P., *J. Virol.* **62**, 4686–4690 (1988).
14. VLASAK, R., LUYTJES, W., SPAAN, W., and PALESE, P., *Proc. Natl. Acad. Sci. USA* **85**, 4526–4529 (1988).
15. VLASAK, R., MUSTER, T., LAURO, A. M., POWERS, J. C., and PALESE, P., *J. Virol.* **63**, 2056–2062 (1989).
16. YOKOMORI, K., LA MONICA, N., MAKINO, S., SHIEH, C. K., and LAI, M. M. C., *Virology* **173**, 683–691 (1989).
17. HERRLER, G., ROTT, R., KLENK, H.-D., MUELLER, H.-P., SHUKLA, A. K., and SCHAUER, R., *EMBO J.* **4**, 1503–1506 (1985).
18. HERRLER, G., ROTT, R., and KLENK, H.-D., *Virology* **141**, 144–147 (1985).
19. HERRLER, G., DURKOP, I., BECHT, H., and KLENK, H.-D., *J. Gen. Virol.* **69**, 839–846 (1988).
20. SCHULTZE, B., WAHN, K., KLENK, H.-D., and HERRLER, G., *Virology* **180**, 221–228 (1991).
21. DEREGT, D., and BABIUK, L. A., *Virology* **68**, 410–420 (1987).
22. DEREGT, D., GIFFORD, G. A., IJAZ, M. K., WATTS, T. C., GILCHRIST, J. E., HAINES, D. M., BABIUK, L. A., *J. Gen. Virol.* **70**, 993–998.
23. HOGUE, B. G., KING, B., and BRIAN, D. A., *J. Virol.* **51**, 384–388 (1984).
24. HOGUE, B. G., and BRIAN, D. A., *Virus Res.* **5**, 131–144 (1986).
25. LAPPS, W., and BRIAN, D. A., *Arch. Virol.* **86**, 101–108 (1985).
26. KAMAHORA, T., SOE, L. H., and LAI, M. M. C., *Virus Res.* **12**, 1–9 (1989).
27. ST. CYR-COATS, K., and STORZ, J., *J. Vet. Med.* **B35**, 48–56 (1988).
28. ZHANG, X. M., KOUSOULAS, K. G., and STORZ, J., *Virology* **183**, 397–404 (1991).
29. PARKER, M. D., COX, G. J., DEREGT, D., FITZPATRICK, D. R., and BABIUK, L. A., *J. Gen. Virol.* **70**, 155–164 (1989).
30. KIENZLE, T. E., ABRAHAM, S., HOGUE, B. G., and BRIAN, D. A., *J. Virol.* **64**, 1834–1838 (1990).
31. PERLMAN, D., and HALVORSON, H. O., *J. Mol. Biol.* **167**, 391–409 (1983).
32. NAKADA, S., CREAGER, R. S., KRYSAL, M., AARONSON, R. P., and PALESE, P., *J. Virol.* **50**, 118–124 (1984).
33. STORZ, J., and ZHANG, X. M., *Behring Inst. Mitt.* **89**, 130–137 (1991).
34. HAJER, I., and STORZ, J., *Am. J. Vet. Res.* **39**, 441–444 (1978).
35. STORZ, J., and ROTT, R., *Med. Microbiol. Immunol.* **169**, 169–178 (1981).
36. HERRLER, G., and KLENK, H.-D., *Virology* **159**, 102–108 (1987).
37. HERRLER, G., MÜLTHAUP, G., BEYREUTHER, K., and KLENK, H. D., *Arch. Virol.* **102**, 269–274 (1988).
38. ROGER, G. N., HERRLER, G., PAULSON, J. C., and KLENK, H.-D., *J. Biol. Chem.* **261**, 5947–5951 (1986).
39. BOYLE, J. F., WEISMILLER, D. G., and HOLMES, K. V., *J. Virol.* **61**, 185–189 (1987).
40. DEA, S., VERBEEK, A. J., and TIJSSEN, P., *J. Virol.* **64**, 3112–3118 (1990).
41. SCHOLTISSEK, C., BUERGER, H., BACHMANN, P. A., and HANNOUN, C., *Virology* **129**, 521–523 (1983).
42. GUO, Y. J., JIN, F. G., WANG, P., WANG, M., and ZHU, J. M., *J. Gen. Virol.* **41**, 115–127.
43. SANGER, F., NICKLEN, S., and COULSON, A. R., *Proc. Natl. Acad. Sci. USA* **74**, 5463–5467 (1977).
44. ZHANG, X. M., KOUSOULAS, K. G., and STORZ, J., *Virology* **185**, 847–852 (1991).