

Detection of Bovine Coronavirus by Enzyme-Linked Immunosorbent Assay using Monoclonal Antibodies

Mitsuo SATO and Hiroomi AKASHI¹⁾

Utsunomiya Livestock Hygiene Service Center, 2-3-39 Wakakusa, Utsunomiya, Tochigi 320 and ¹⁾National Institute of Animal Health, 3-1-1 Kannondai, Tsukuba, Ibaraki 305, Japan

(Received 2 February 1993/Accepted 1 June 1993)

ABSTRACT. A sensitive and highly specific enzyme-linked immunosorbent assay (ELISA) system for detection of bovine coronavirus was developed using monoclonal antibodies, which showed both neutralization and hemagglutination inhibition activities. A monoclonal antibody was coated onto microplates for capturing antigen and a mixture of two monoclonal antibodies served as detecting antibodies. Using this assay, 40 of 202 fecal specimens from 29 herds were shown to be positive for viral antigen. From 10 ELISA positive specimens from 5 herds, the virus was isolated after several passages on human rectal adenocarcinoma (HRT-18) cell culture.—**KEY WORDS:** bovine coronavirus, ELISA, monoclonal antibody.

J. Vet. Med. Sci. 55(5): 771-774, 1993

Bovine coronavirus (BCV) is the primary pathogen in neonatal calf diarrhea [3, 13-15, 18, 22] and epizootic diarrhea in adult cattle [2, 11, 17, 23]. BCV is difficult to isolate from diarrheal feces, and detection of viral particles from diarrheal feces by electron microscopy or antibody by serology is required for diagnosis. Attempts have been made to develop an ELISA system for detection of the virus from feces with little success [5, 6, 16, 24]. Herein we describe a useful ELISA system for detection of BCV from fecal specimens using two monoclonal antibodies (MoAbs) against the Kakegawa strain of BCV [1] showing both neutralization (NT) and hemagglutination inhibition (HI) activities.

MATERIALS AND METHODS

Reference virus: The Kakegawa strain of BCV was grown in BEK-1 cells [12]. The infected culture supernatant was concentrated approximately 60 times by dialysis against AG gum powder, and after centrifugation at 3,000 rpm for 20 min, the resulting supernatant was stored at -80°C until use. The purified viral antigen was prepared according to the method described previously [1], and used at a dilution showing 64 hemagglutinating units.

Virus isolation from fecal specimens: Fecal specimens were collected from 1989 to 1991 from calves and adult cattle with diarrhea at the farms mostly located in the northern part of Tochigi Prefecture. As negative controls specimens were collected from 25 calves without diarrhea from one herd. The specimens were diluted from 1:5 to 1:10 with phosphate buffered saline (PBS) and stored at -80°C. For ELISA and virus isolation, the supernatants were used after centrifugation at $2,200 \times g$ for 20 min. Then, the specimens were inoculated onto monolayers of HRT-18 [25] and Vero cells grown in roller tubes containing growth or maintenance medium [12]. The maintenance medium for Vero cells contained 2 $\mu\text{g/ml}$ of

trypsin. The cell cultures were observed daily for cytopathic effect (CPE), and blind passages were performed at least 3 times in case of no evidence for CPE. At each passage the inoculated culture supernatant was measured for ELISA optical density (OD) values described below.

NT and HI tests: The NT test was performed on BEK-1 cell cultures [1]. The HI test was carried out by using 96-well microplates according to the modified procedures of Sato *et al.* [20].

MoAbs: The two MoAbs, 4H4 and 7F5, utilized in this study exhibited a high titer against BCV in both ELISA and HI tests, and both reacted with a polypeptide having a molecular weight of 93 kilodalton (kDa). However, they showed different reactivities in the NT test [21]. The two antibodies recognized different viral epitopes by the competitive binding assay (data not shown). The two MoAbs had originated from tissue culture fluid without serum, and were concentrated into one-twentieth volume by a method described previously. The total protein concentration was estimated by Lowry's method. MoAbs were biotinylated with N-Hydroxysuccinimidobiotin (Pierce Chemical, Co., U.S.A.) by the method of Hofmann *et al.* [10]. For coating plates, MoAbs were diluted to a concentration of 2 $\mu\text{g/ml}$ with 0.05 M bicarbonate buffer, pH 9.6, and the dilution was distributed onto 96-well ELISA plates (Greiner, Germany) at 4°C overnight. The plates were then washed twice with PBS containing 0.05% Tween 20 (Tween-PBS), and subsequently treated with Tween-PBS containing 0.5% egg albumin, pH 7.2 (E-PBS), at room temperature for 1 hr. After washing with Tween-PBS, they were dried at room temperature and stored at -80°C until use.

ELISA: One hundred microliters of test fecal specimens were distributed into duplicate wells of the MoAb-coated plates and incubated at 37°C for 1 hr. Then the plates were washed three times with Tween-PBS. The biotinylated MoAb was diluted with E-PBS and 50 μl was added to each well. After incubation for 30 min at 37°C, the plates

were washed and then 50 μ l of a 1:2,000 dilution of peroxidase conjugated streptavidin (ZYMED Laboratories, Inc., U.S.A.) with E-PBS was applied in each well. The plates were incubated at 37°C for 30 min, then washed again three times and 100 μ l of a substrate solution containing 1.46 mM 2,2'-azino-bis (3-ethylbenzo thiazoline-6-sulfonic acid) and 0.28 mM hydrogen peroxide (pH 4.0) were applied to each well. After incubation at room temperature for 30 min, the reaction was stopped with 50 μ l of 0.1 N NaOH and the OD values at 405 nm were read.

RESULTS

Nine combinations of MoAb for antigen capture with that for its detection shown in Fig. 1 were tested for efficiency of viral antigen capture and detection antibodies.

With the purified Kakegawa antigen combination No. 1 (C1) showed very low sensitivity and C5 showed a higher background (Fig. 2). The combinations C4, C6 and C9 in Fig. 2, gave better results and clear reaction curves, and there was little difference among these three combinations. The most effective was a combination of 7F5 for antigen capture with a mixture of 4H4 and 7F5 (1:1) for its detection. Using a higher concentration of biotinylated MoAbs, a higher background was observed, and optimal dilution of biotinylated MoAb was determined to be 3 μ g/ml (Fig. 3). Little enhancement of sensitivity was observed with a higher concentration of coating MoAb, the detection limit of the ELISA system corresponded to

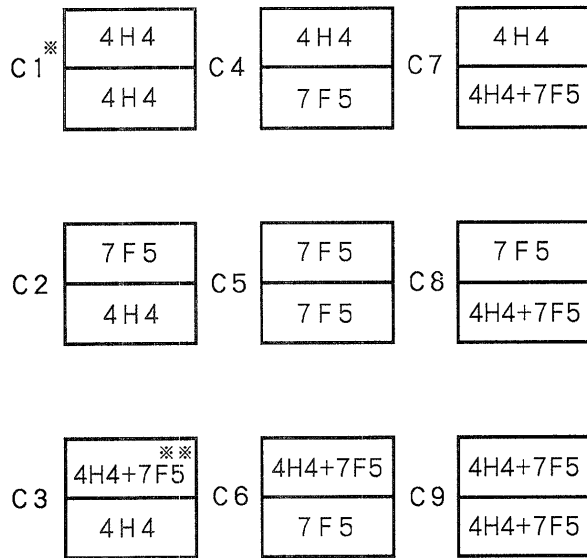

* Combination No.

** 1:1

Fig. 1. Combination of monoclonal antibodies (MoAbs) in ELISA. Upper and lower boxes show biotinylated MoAb for antigen capture and coating MoAb (2 μ g/ml) for virus detection, respectively.

about one HA unit or a TCID₅₀ of 1 \times 10⁴.

Next, the detectability of the viral antigen in the infected HRT-18 cell culture was studied. The infected

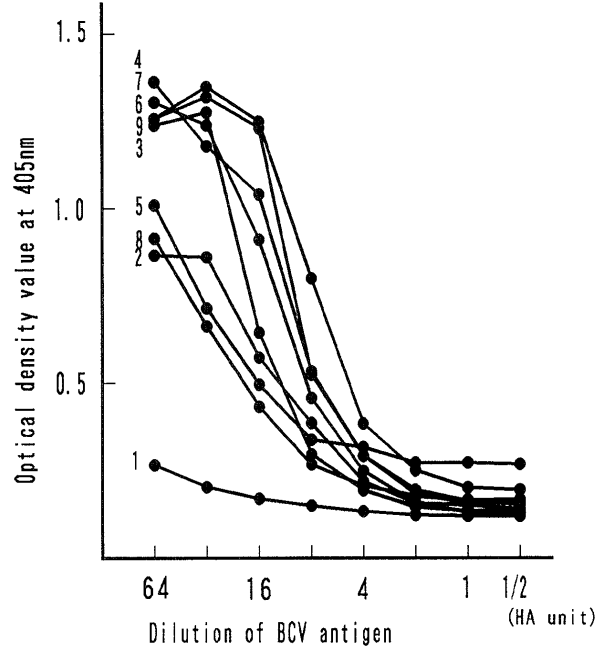

Fig. 2. Titration curves of BCV antigen obtained with different combinations of MoAbs. Each number represents the combination presented in Fig. 1. Three micrograms per ml of biotinylated MoAbs was used.

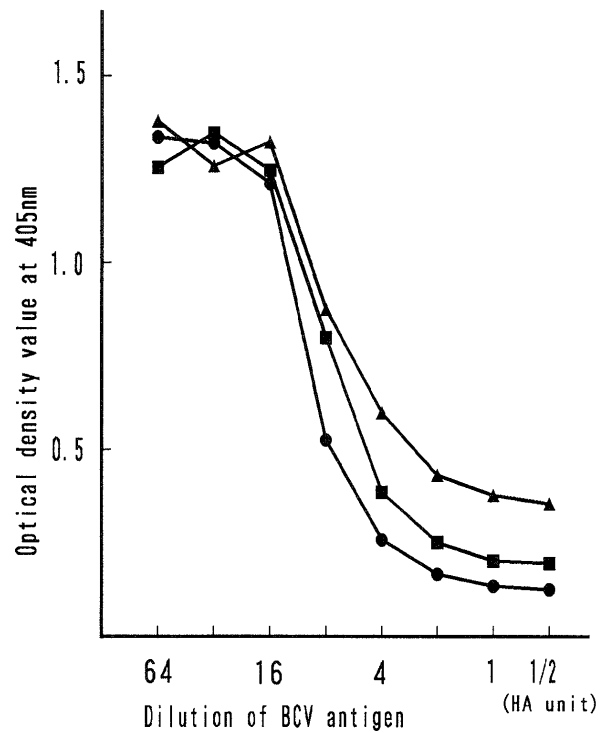

Fig. 3. Titration curves of the Kakegawa strain of BCV antigen in ELISA using different concentrations of biotinylated MoAbs: 1.5 (-●-), 3 (-■-) and 6 μ g/ml (-▲-) of biotinylated MoAbs.

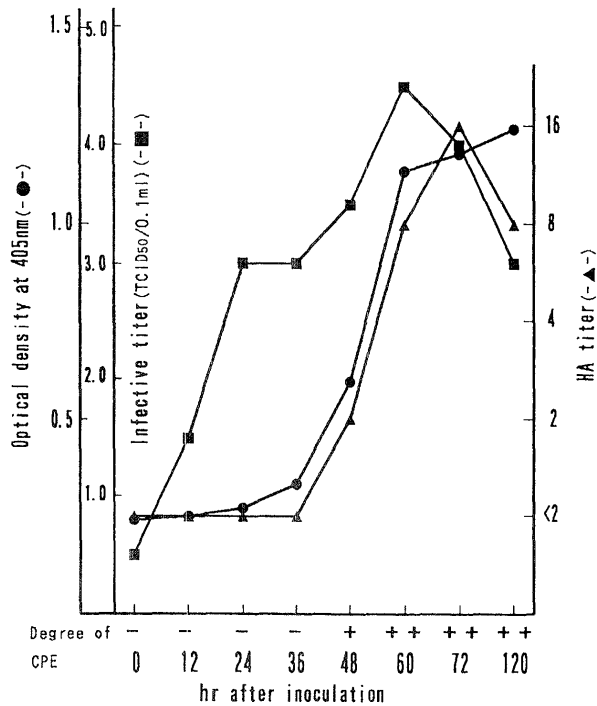

Fig. 4. Development of ELISA and HA antigenicity and infectivity of BCV in HRT-18 cell cultures. The infected culture supernatant was harvested 12 to 120 hr pi, and tested for ELISA titer, which was compared with HA antigenicity and infectivity titers.

Table 1. Detection of BCV antigen by ELISA from 202 fecal samples of 29 herds

	OD values				total
	<0.2	0.2≤	0.3≤	0.5<	
Test samples	162 ^{a)}	27	6	7 ^{b)}	202
Virus isolation	1 ^{c)}	3 ^{c)}	1	5	10

- a) Number of cases.
- b) Calves with diarrhea.
- c) Adult with diarrhea.

culture supernatant of HRT-18 cells with the Kakegawa strain was harvested at 12 to 120 hr post-inoculation (pi), and the OD values were compared with infectivity titers and HA units (Fig. 4). Peak titers of infectivity and HA activity were seen at 60 and 70 hr pi, respectively, and gradually decreased thereafter. Viral antigen was detected at 36 hr pi by ELISA, showing the highest titer at 60 hr pi which remained up to 120 hr pi. CPE appeared very slightly at 48 hr pi. The detection limit was almost of the same level as purified viral antigen.

Table 1 shows the results of ELISA with 202 fecal samples. One hundred and sixty two samples (80%) including most specimens collected from non-diarrheal calves showed OD values of 0.2 or less. On the other hand, 7 specimens from calves with diarrhea showed OD values of over 0.5, and the virus was isolated from five of

the 7 calves. Other isolates were from adult Japanese beef cattle showing OD values of 0.1 to 0.3.

The virus was isolated from 10 fecal specimens from 5 herds. Six of the 10 specimens were from calves with diarrhea, while 4 samples from adult cattle with semiliquid diarrhea of the same herd. The HRT-18 cell culture supernatant inoculated with each sample increased in OD value with the passage. The CPE was characterized by slight granulation and swelling at the third passage, becoming more clear after five passages. The isolates were identified by NT and immunofluorescence using rabbit hyperimmune serum against the Kakegawa strain of BCV. Concomitantly with BCV, the group A bovine rotaviruses were also isolated from five of six diarrheal calves.

DISCUSSION

The two MoAbs used in this study react with a polypeptide having a molecular weight of 93 kDa, presumably of the outer surface protein of BCV. Using mouse polyclonal immune serum and MoAbs reacting with a 52 kDa polypeptide of BCV, combination ELISA was tested without success because of low sensitivity (data not shown). However, the combination ELISA of 7F5 as an antigen-capture antibody with a mixture of 4H4 and 7F5 monoclonal antibodies as detecting antibodies was successful. Some researchers [5, 6, 24] reported application of ELISA to the experimental or natural BCV infection using polyclonal and monoclonal antibodies which have neutralizing activity. They demonstrated the efficiency of their tests to compare only with the electron microscopic observation, which was difficult to interpret because of the existence of fringed particles in diarrheal feces.

Application of this ELISA system to diarrheal fecal samples from 29 herds resulted in the isolation of 10 cytopathic agents, which were serologically identical to BCV. Six of the 10 samples showing OD values over 0.5 were from calves with diarrhea, while the virus was isolated from diarrheal feces of adult Japanese beef cattle showing relatively low OD values ranging from 0.1 and 0.3. Crouch and Acres reported the detection of BCV in complex with IgG from feces from apparently normal cattle [4], suggesting that copro immunoglobulin combined with the virus particles might affect the detectability of the viral antigen by ELISA. Although El-Ghorr *et al.* [9] reported serological variation in the HI test among the BCV strains, no comparative antigenicity was studied with the present 10 isolates.

The primary bovine kidney cell culture or established cell lines have been used for the isolation of BCV from diarrheal feces with much difficulty, although there are some reports on the isolation of coronaviruses using HRT-18 cell cultures [2, 7]. In the present study, by monitoring for the presence of the antigen by ELISA we could isolate BCV in HRT-18 cell cultures more effectively from diarrheal feces. Trypsin treatment has been reported to enhance the CPE [7, 8, 19]. The cell fusion in

HRT-18 cells was enhanced in the presence of trypsin (data not shown). However, in this study the treatment with trypsin diminished the reactivity of the specimens in ELISA.

The group A bovine rotavirus was isolated from diarrheal feces of 5 calves affected with BCV, and most of them showed severe symptoms. Two calves died of diarrhea, indicating the complexity of infectious calf diarrhea as well as the difficulty in diagnosis of the outbreak.

The proposed technique of ELISA with MoAbs proved to be a very rapid and quantitative method for BCV, the detection limit of which corresponds to a TCID₅₀ of 1×10^4 or about one HA unit. Application of the ELISA assay to field fecal specimens is considered to be a highly useful tool not only for routine diagnosis of BCV but also for isolation of the virus from diarrheal feces.

REFERENCES

- Akashi, H., Inaba, Y., Miura, Y., Tokuhisa, S., Sato, K., and Satoda, K. 1980. Properties of a coronavirus isolated from a cow with epizootic diarrhea. *Vet. Microbiol.* 5: 265-276.
- Benfield, D. A. and Saif, L. J. 1990. Cell culture propagation of a coronavirus isolated from cows with winter dysentery. *J. Clin. Microbiol.* 28: 1454-1457.
- Bridger, J. C., Woode, G. N., and Meyling, A. 1978. Isolation of coronaviruses from neonatal calf diarrhea in Great Britain and Denmark. *Vet. Microbiol.* 3: 101-113.
- Crouch, C. F. and Acres, S. D. 1984. Prevalence of rotavirus and coronavirus antigens in the feces of normal cows. *Can. J. Comp. Med.* 48: 340-342.
- Crouch, C. F., Raybould, T. J. G., and Acres, S. D. 1984. Monoclonal antibody capture enzyme-linked immunosorbent assay for detection of bovine enteric coronavirus. *J. Clin. Microbiol.* 19: 388-393.
- Czerny, C.-P. and Eichhorn, W. 1989. Characterization of monoclonal and polyclonal antibodies to bovine enteric coronavirus: Establishment of an efficient ELISA for antigen detection in feces. *Vet. Microbiol.* 20: 111-122.
- Dea, S., Garzon, S., and Tijssen, P. 1989. Isolation and trypsin-enhanced propagation of turkey enteric (bluecomb) coronaviruses in a continuous human rectal adenocarcinoma cell line. *Am. J. Vet. Res.* 50: 1310-1318.
- Dea, S., Roy, R. S., and Begin, M. E. 1980. Bovine coronavirus isolation and cultivation in continuous cell lines. *Am. J. Vet. Res.* 41: 30-38.
- El-Ghorr, A. A., Snodgrass, D. R., Scott, F. M. M., and Campbell, I. 1989. A serological comparison of bovine coronavirus strains. *Arch. Virol.* 104: 241-248.
- Guesdon, J.-L., Ternynck, T., and Avrameas, S. 1979. The use of avidin-biotin interaction in immunoenzymatic techniques. *J. Histochem. Cytochem.* 27: 1131-1139.
- Horner, G. W., Hunter, R., and Kirkbride, C. A. 1975. A coronavirus-like agent present in faeces of cows with diarrhoea. *N. Z. Vet. J.* 23: 98.
- Inaba, Y., Sato, K., Kurogi, H., Takahashi, E., Ito, Y., Omori, T., Goto, Y., and Matumoto, M. 1976. Replication of bovine coronavirus in cell line BEK-1 culture. *Arch. Virol.* 50: 339-342.
- Langpap, T. J., Bergeland, M. E., and Reed, D. E. 1979. Coronaviral enteritis of young calves: Virologic and pathologic findings in naturally occurring infections. *Am. J. Vet. Res.* 40: 1476-1478.
- Mebus, C. A., Stair, E. L., Rhodes, M. B., and Twiehaus, M. J. 1973. Neonatal calf diarrhea: Propagation, attenuation and characteristics of a coronavirus-like agent. *Am. J. Vet. Res.* 34: 145-150.
- Morin, M., Lamothe, P., Gagnon, A., and Malo, R. 1974. A case of viral neonatal calf diarrhea in a Quebec dairy herd. *Can. J. Comp. Med.* 38: 236-242.
- Reynolds, D. J., Chasey, D., Scott, A. C., and Bridger, J. C. 1984. Evaluation of ELISA and electron microscopy for the detection of coronavirus and rotavirus in bovine faeces. *Vet. Rec.* 114: 397-401.
- Saif, L. J., Brock, K. V., Redman, D. R., and Kohler, E. M. 1991. Winter dysentery in dairy herds: Electron microscopic and serological evidence for an association with coronavirus infection. *Vet. Rec.* 128: 447-449.
- Stair, E. L., Rhodes, M. B., White, R. G., and Mebus, C. A. 1972. Neonatal calf diarrhea: Purification and electron microscopy of a coronavirus-like agent. *Am. J. Vet. Res.* 33: 1147-1156.
- Storz, J., Rott, R., and Kaluza, G. 1981. Enhancement of plaque formation and cell fusion of an enteropathogenic coronavirus by trypsin treatment. *Infect. Immun.* 31: 1214-1222.
- Sato, K., Inaba, Y., Kurogi, H., Takahashi, E., Satoda, K., Omori, T., and Matumoto, M. 1977. Hemagglutination by calf diarrhea coronavirus. *Vet. Microbiol.* 2: 83-87.
- Sato, M., Akashi, H., Hirai, S., Kimura, Y., and Takahashi, M. 1991. Production of monoclonal antibodies against the Kakegawa strain of bovine coronavirus and their characterization. *J. Vet. Med. Sci.* 53: 147-148.
- Sharpee, R. L., Mebus, C. A., and Bass, E. P. 1976. Characterization of a calf diarrheal coronavirus. *Am. J. Vet. Res.* 37: 1031-1041.
- Takahashi, E., Inaba, Y., Sato, K., Ito, Y., Kurogi, H., Akashi, H., Satoda, K., and Omori, T. 1980. Epizootic diarrhoea of adult cattle associated with a coronavirus-like agent. *Vet. Microbiol.* 5: 151-154.
- Thorns, C. J., Bell, M. M., Chasey, D., Chesham, J., and Roeder, P. L. 1992. Development of monoclonal antibody ELISA for simultaneous detection of bovine coronavirus, rotavirus serogroup A, and *Escherichia coli* K99 antigen in feces of calves. *Am. J. Vet. Res.* 53: 36-43.
- Tompkins, W. A. F., Watrach, A. M., Schmale, J. D., Shultz, R. M., and Harris, J. A. 1974. Cultural and antigenic properties of newly established cell strains derived from adenocarcinomas of the human colon and rectum. *J. Natl. Cancer Inst.* 52: 1101-1110.